

MOD. SNM01

Sensore segnamarce Gear sensor

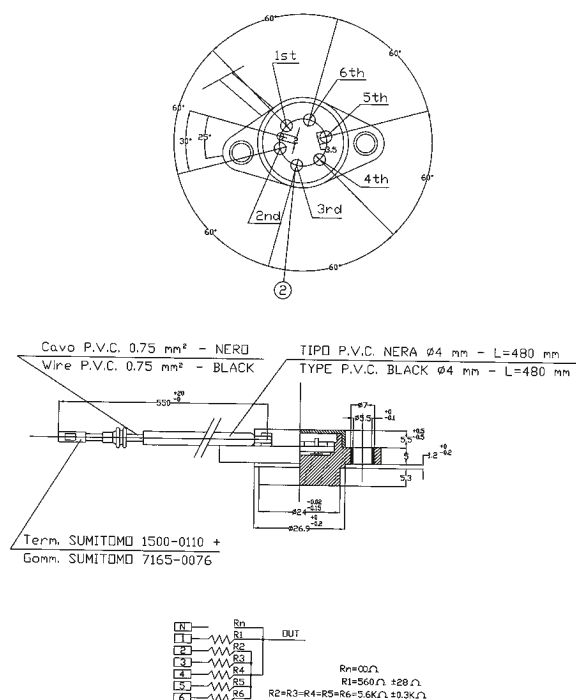

SCHEDA TECNICA

Caratteristiche elettriche

Massima potenza di lavoro	0,125 VA
Massima tensione	12 V

Caratteristiche meccaniche

Corpo	PPS
Contatti	ottone
Fissaggio	Flangia a 2 fori
Tipo di contatto variabile	Elettromeccanico a resistenza
Peso	~ 50 g

TECHNICAL DATA

Electrical characteristics

Max. working power	0,125 VA
Max. supply voltage	12 V

Mechanical characteristics

Body	PPS
Contacts	ottone
Fixing	Flangia a 2 fori
Connections	Elettromeccanico a resistenza variabile
Weight	~ 50 g