

MOD. A4 Sensore di livello carburante resistivo Resistive fuel level sensor

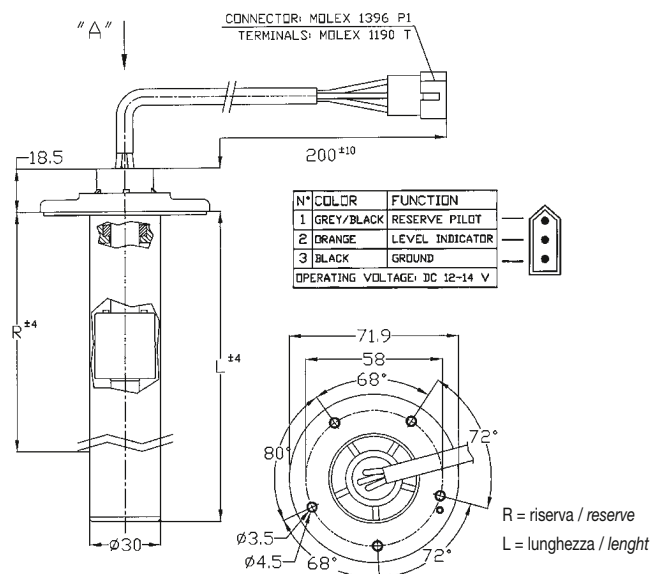

• Impiego	Gasolio - Benzina
• Fissaggio	Flangia 5 fori Nylon
• Contro flangia	Acciaio Zincato
• Camera di calma	Nylon
• Galleggiante	Nylon espanso
• Guarnizione di tenuta	Gomma anti-idrocarburi
• Contatto mobile	Bronzo fosforoso dorato
• Circuito stampato	FR4 dorato
• Uscita cablaggio*	200 mm con connettore
• Tenuta cavi	Resina epossidica
• Peso specifico liquido	> 0,7
• Valore OHM	Vuoto 90 Ω
	Pieno 10 Ω
• Peso	~ 120 gr (Per L= 200mm)

• Use	Diesel fuel - Petrol
• Fixing	5 holes Nylon flange
• Counter flange	Zinc plated steel
• Stabilized room	Nylon
• Float	Foamed nylon
• Gasket seal	Petrol - proof rubber
• Sliding contact	Gold Plated Phosphorous bronze
• Printed circuit	FR4 Gold Plated
• Wiring output*	200 mm with connector
• Cables seal	Epoxy resin
• Fluid specific weight	> 0,7
• OHM Value	Empty 90 Ω
	Full 10 Ω
• Weight	~ 120 gr (for L= 200 mm)

Lunghezza - Length L [mm]	Riserva - Reserve R [mm]
165,0	123,0
234,0	203,5

* Per versioni personalizzate (lunghezza, tipo di cablaggio, ecc.) contattare i nostri servizi commerciali
For customized version (length, type of cable, etc.) please contact our customer service

Per un corretto impiego vedere le note generali del catalogo sensori Euroswitch edizione 10/2010.
For a correct use please refer to "General Notes" in the Euroswitch sensors catalogue, edition 10/2010.