

## MOD. B2 Sensore di livello carburante resistivo Resistive fuel level sensor

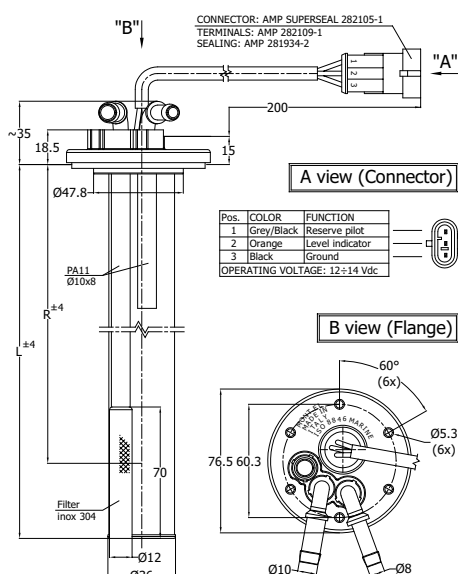

• Impiego	Gasolio - Benzina
• Fissaggio	Flangia in nylon 6 fori
• Camera di calma	Alluminio
• Tubi di aspirazione	PA 11
• Galleggiante	Nylon espanso
• Guarnizione di tenuta	Gomma resistente agli idrocarburi
• Contatto mobile	Bronzo fosforoso dorato
• Uscita cablaggio*	200 mm con connettore
• Circuito stampato	FR4 dorato
• Tenuta cavi	Resina epossidica
• Peso specifico liquido	> 0,7
• Valore OHM	Pieno 7 Ω Vuoto 315 Ω (tab 1)
	Pieno 180 Ω Vuoto 5 Ω (tab 2)

• Use	Diesel fuel - Petrol
• Fixing	6 holes Nylon flange
• Stabilized room	Aluminum
• Suction pipe	PA 11
• Float	Foamed nylon
• Gasket seal	Petrol - proof rubber
• Moving contact	Gold Plated Phosphorous bronze
• Wiring output*	200 mm with connector
• Printed circuit	FR4 Gold Plated
• Cables seal	Epoxy resin
• Fluid specific weight	> 0,7
• OHM Value	Full 7 Ω Empty 315 Ω (tab 1)
	Full 180 Ω Empty 5 Ω (tab 2)

Tab 1

Pieno 7 Ω Full	L [mm]	176	186	210	225	257	267	285	290	326	355	374	399	424	452	460	505
	R [mm]	141	150	158	191	230	238	208	262	289	322	315	361	395	341	380	456

Tab 2

Pieno 180 Ω Full	L [mm]	176	186	210	225	257	267	285	290	326	355	375	391	424	452	464	505
	R [mm]	141	150	158	191	230	238	208	262	289	322	321	331	395	341	399	456

\* Per versioni personalizzate (tubi di aspirazione, tipo di cablaggio, lunghezze, ecc.) contattare i nostri servizi commerciali  
For customized version (suction pipe, type of cable, length, etc.) please contact our customer service

Per un corretto impiego vedere le note generali del catalogo sensori Euroswitch edizione 10/2010.  
For a correct use please refer to "General Notes" in the Euroswitch sensors catalogue, edition 10/2010.