

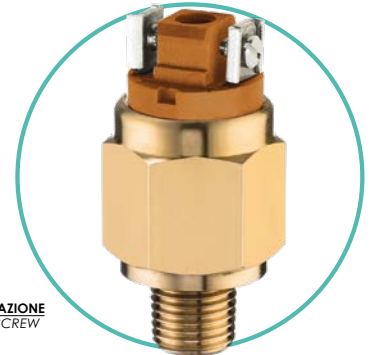

35

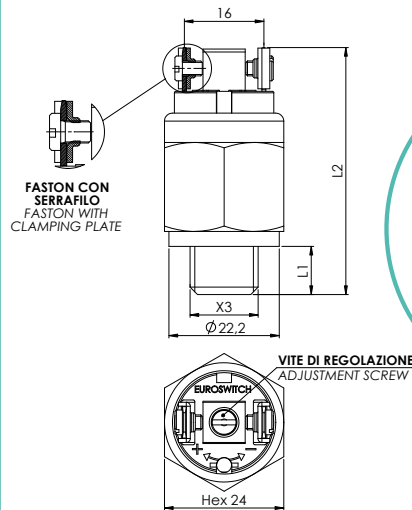
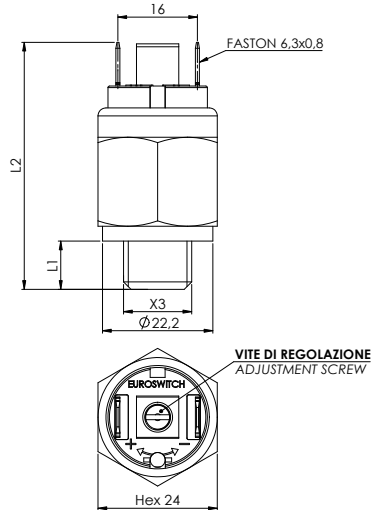

35V

Codice Part number		Campo di regolazione Setting range mbar	Tolleranza a 20°C Tolerance at 20°C mbar
Contatto elettrico norm. aperto Electrical contact norm. open	1		
Contatto elettrico norm. chiuso Electrical contact norm. closed	2		
35(V) 1 ▲ ● ■ 9	35(V) 2 ▲ ● ■ 9	-200 / -900	± 100

(V) = versione faston con serrafilo / faston with clamping plate

▲ Materiale Corpo Attacco a processo Case Material Thread connection
1 Ottone 1 Brass
2 Acciaio Inox AISI 316L* 2 Stainless steel AISI 316L*

\* Standard G1/4" cilindrico. \* Standard G1/4" cylindrical

● Filetti Threads	L1mm	L2mm
1 - 1/8" Gas conico 1 - 1/8" Gas conical	10	50
2 - 1/4" Gas conico 2 - 1/4" Gas conical	12	52
3 - M10x1 conico 3 - M10x1 conical	10	50
5 - 1/8" NPT 5 - 1/8" NPT	10	50
4 - M12x1,5 Cilindrico 4 - M12x1,5 cylindrical	9	50
6 - 1/4" Gas cilindrico 6 - 1/4" Gas cylindrical	9.7	50.7
G - 1/8" Gas cilindrico G - 1/8" Gas cylindrical	10	51

■ Membrane (vedi pag. 19) Diaphragms (see page 19)
1 NBR (standard)
2 FKM
3 EPDM
4 CR
6 HNBR

Contatti elettrici Electric contacts	Argento AgNi, (a richiesta dorati) Silver AgNi, (gold plated on request)
Condizione elettrica Electrical condition	N.A. (colore naturale) N.C. (ocra) N.O. (natural color) N.C. (ochre)
Max tensione commutabile Max switched voltage	48V ac / dc
Max corrente commutabile Max switched current	0.5A (a richiesta 2A) 0.5A (2A on request)
Max temperatura fluido Max fluid temperature	80°-120°C (in funzione della membrana) 80°-120°C (depending on diaphragm)
Max pressione di sicurezza Max Overpressure limit	15 bar
Massima pressione di lavoro Max Working pressure	10 bar

Tipo di azionamento Action type	1B
Vita meccanica Mechanical working life	10 <sup>6</sup> operazioni 10 <sup>6</sup> operations
Vita elettrica Electrical working life	10 <sup>6</sup> operazioni 10 <sup>6</sup> operations
Grado di protezione Protection degree	IP 00 (vedi pag. 20-22 per cappucci e connettori di protezione) IP 00 (see pages 20-22 for protection caps and connectors)
Peso Weight	~ 70 g