

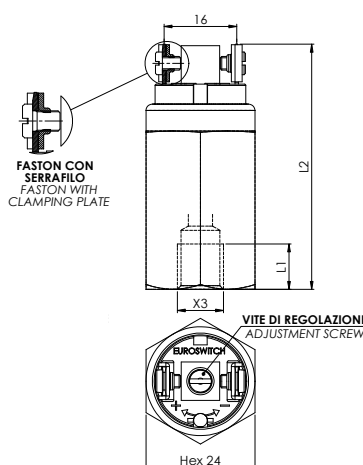

42

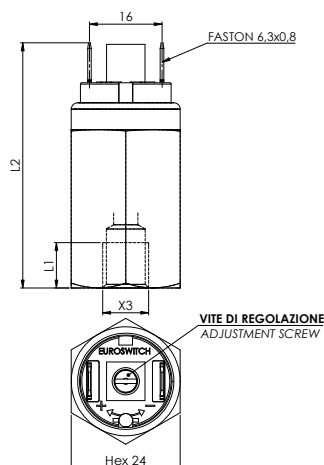

42V

Codice Part number		Campo di regolazione Setting range bar	Tolleranza a 20°C Tolerance at 20°C bar
Contatto elettrico norm. aperto Electrical contact norm. open	Contatto elettrico norm. chiuso Electrical contact norm. closed		
42(V) 1 ▲ ● ■ 0	42(V) 2 ▲ ● ■ 0	0.1 - 1	± 0.1
42(V) 1 ▲ ● ■ A	42(V) 2 ▲ ● ■ A	0.2 - 2	± 0.15
42(V) 1 ▲ ● ■ 1	42(V) 2 ▲ ● ■ 1	1 - 5	± 0.3
42(V) 1 ▲ ● ■ 2	42(V) 2 ▲ ● ■ 2	1 - 10	± 0.5
42(V) 1 ▲ ● ■ 3	42(V) 2 ▲ ● ■ 3	10 - 20	± 1.0
42(V) 1 ▲ ● ■ 4	42(V) 2 ▲ ● ■ 4	20 - 50 ⁽¹⁾	± 2.0

(V) = versione faston con serrafilo / faston with clamping plate

⁽¹⁾ Versione fornibile solo con corpo in acciaio zincato / Inox AISI - Available only with body Zinc plated or Stainless steel

▲ Materiale Corpo Attacco a processo Case Material Thread connection
0 Acciaio Zincato 0 Zinc plated steel case
1 Ottone 1 Brass
2 Acciaio Inox AISI 316* 2 Stainless steel AISI 316*
5 Acciaio Inox AISI 303* 5 Stainless steel AISI 303*

● Filetti Threads
4 - M12x1.5 Cilindrico 4 - M12x1.5 cylindrical
6 - 1/4" Gas cilindrico 6 - 1/4" Gas cylindrical
8 - M10x1 cilindrico 8 - M10x1 cylindrical
G - 1/8" Gas cilindrico G - 1/8" Gas cylindrical

■ Membrane (vedi pag. 19) Diaphragms (see page 19)
1 NBR
2 FKM (standard)
3 EPDM
4 CR
5 - Silicone
6 HNBR

* Standard G1/4" cilindrico * Standard G1/4" cylindrical

Contatti elettrici Electric contacts	Argento AgNi, (a richiesta dorati) Silver AgNi, (gold plated on request)
Condizione elettrica Electrical condition	N.A. (bordeaux) o N.C. (blu) N.O. (bordeaux) or N.C. (blue)
Max tensione commutabile Max switched voltage	48 V ac / dc
Max corrente commutabile Max switched current	0.5 A (a richiesta 2A) 0.5 A (2A on request)
Max temperatura fluido Max fluid temperature	80° a 120°C (in funzione della membrana) 80° to 120°C (depending on diaphragm)
Vita meccanica Mechanical working life	10 ⁶ operazioni 10 ⁶ operations
Vita elettrica Electrical working life	10 ⁶ operazioni 10 ⁶ operations

Max pressione di sicurezza Max Overpressure limit	Acciaio zincato / Inox 300 bar Ottone 80 bar Zinc plated steel / St. steel 300 bar Brass 80 bar
Max pressione di lavoro Max Working pressure	Acciaio zincato / Inox 150 bar Ottone 40 bar Zinc plated steel / St. steel 150 bar Brass 40 bar
Tipo di azionamento Action type	1B
Grado di protezione Protection degree	IP 00 (vedi pag. 20-22 per cappucci e connettori di protezione) IP 00 (see pages 20-22 for protection caps and connectors)
Peso Weight	~ 125 g