

### PO03F7-100 - F7-500

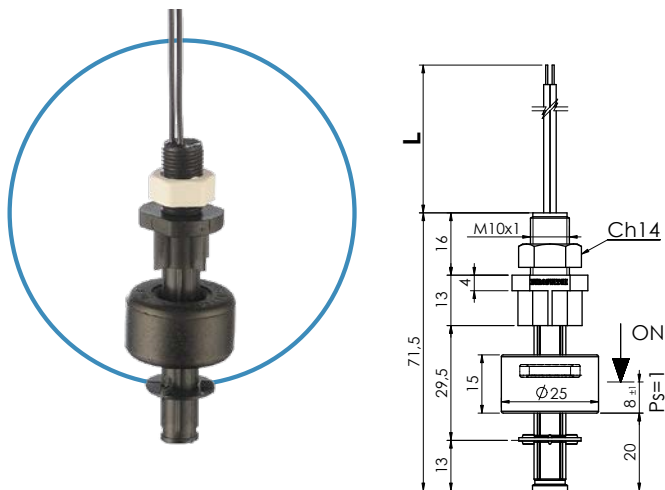

### PO03F7-200 - F7-600

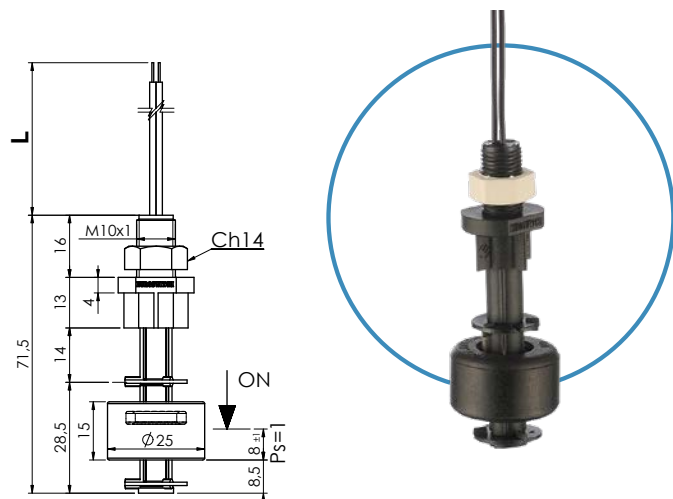

		Codice Part number		
<b>Connessione elettrica</b> <i>Electrical connection</i>				
<b>L = 500 mm fili/wires</b>	PO03F7 - 100	PO03F7 - 200	PO03F7 - 500	PO03F7 - 600
<b>L = 1 mt cavetto/cable</b>	PO03F7 - 110	PO03F7 - 210	PO03F7 - 510	PO03F7 - 610
<b>L = 2 mt cavetto/cable</b>	PO03F7 - 120	PO03F7 - 220	PO03F7 - 520	PO03F7 - 620
Per passare da N.C. a N.A. è sufficiente capovolgere il galleggiante <i>The contact can be converted from N.C. to N.O. by rotating the float upside down</i>			Contatto SPDT <i>SPDT Contact</i>	

Nel caso di connessioni non isolate devono essere prese le adeguate precauzioni per garantire la distanza minima di sicurezza tra i diversi morsetti.  
Per versioni personalizzate (tipo di cablaggio, temperatura > 100°C, tensione > 50V, ecc.) contattare Euroswitch.

*When using non-insulated connections, the necessary precautions must be taken to ensure the minimum safety distance between the terminals.  
For Customized version (type of cable, temperature > 100°C, voltage > 50V, etc.) please contact Euroswitch.*

<b>Impiego</b> <i>Use</i>	<b>Oli minerali - Gasolio - Benzina</b> <i>Mineral Oils - Diesel fuel - Petrol</i>
<b>Fissaggio</b> <i>Fixing</i>	<b>M10 x 1</b>
<b>Stelo</b> <i>Stem</i>	<b>Nylon</b>
<b>Galleggiante</b> <i>Float</i>	<b>NBR</b>
<b>Dado</b> <i>Nut</i>	<b>Nylon</b>
<b>Tipo contatto</b> <i>Type of contact</i>	<b>Reed N.A./N.C. (SPDT)</b> <i>Reed N.O./N.C. (SPDT)</i>

<b>Max potenza commut.</b> <i>Max switch. capacity</i>	<b>40 W - (3 W SPDT)</b>
<b>Max corrente commut.</b> <i>Max switch. current</i>	<b>1 A - (0,25 A SPDT)</b>
<b>Max tensione commut.</b> <i>Max switch. voltage</i>	<b>50 V (250V a richiesta)</b> <i>50 V (250V on request)</i>
<b>Peso specif. liquido</b> <i>Specific fluid weight</i>	<b>50 V</b>
<b>Temp. in funzionamento</b> <i>Working temperature</i>	<b>-10°C / +100°C</b>
<b>Peso</b> <i>Weight</i>	<b>~ gr 16</b>