

26-266

PRESSOSTATO A TARATURA FISSA FIXED SETTING PRESSURE SWITCH

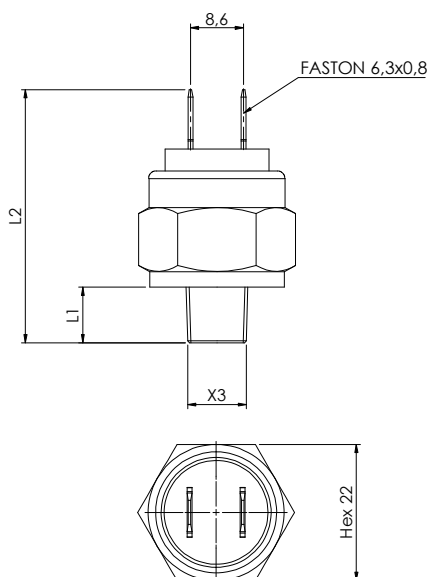

26



266

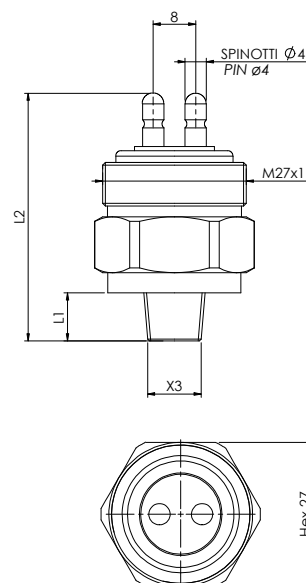

CODICE - PART NUMBER

Mod. 26 - Mod. 266					
contatto elettrico - electrical contact				Campo di intervento Operating range	
norm. aperto norm. open				bar	
26	1	0	0	266	0
26	1	0	1	266	1
				1 - 4	
				3 - 6	

		Mod. 26		Mod. 266	
● Filetti (X3)	Threads (X3)	L1	L2 (mm)	L1	L2 (mm)
1 1/8" Gas conico	1 1/8" Gas conical	8	39	10	48
2 1/4" Gas conico	2 1/4" Gas conical	10	41	12	50
3 M10x1 conico	3 M10x1 conical	9	40	9	47

■ Membrana (vedi pag. 17)	Diaphragm (see page 17)
1 NBR (standard)	1 NBR (standard)
2 FKM	2 FKM
3 EPDM CH	3 EPDM CH
6 HNBR	6 HNBR

Corpo	Acciaio zincato
Contatti elettrici	Argentati
Condizione elettrica	N.A.
Max tensione commutabile	24 V
Max corrente commutabile	2 A
Max temperatura fluido	100° C
Vita meccanica	10 ⁵ operazioni (0 - 200 bar)
Massima pressione di sicurezza	400 bar
Tipo di azionamento	1B
Peso	mod 26 ~ 35 g mod 266 ~ 70 g

Case	Zinc plated steel
Electric contacts	Silver plated
Electric condition	N.O.
Max switched voltage	24 V
Max switched current	2 A
Max fluid temperature	100° C
Mechanical working life	10 ⁵ operations (0 - 200 bar)
Max overpressure limit	400 bar
Action type	1B
Weight	mod 26 ~ 35 g mod 266 ~ 70 g

Contattare Euroswitch per maggiori informazioni sulle versioni disponibili

Please contact Euroswitch for further information on the versions available

Per un corretto impiego vedere le note generali del catalogo pressostati Euroswitch, pag. 11-15. For a correct use please refer to "General Notes" in the pressure switches Euroswitch catalogue, p. 11-15.

L'Azienda si riserva la facoltà di apportare modifiche tecniche ai prodotti o di cessarne la produzione senza obbligo di preavviso. The Company reserves the right to modify the technical features of the products or halt production at any time without notice.